

## BT300 HVAC Drives Electronic Bypass (E-Bypass) Options



### Description

The BT300 Electronic Bypass (E-Bypass) Options are companion packages for the family of BT300 Variable Frequency Drives (VFDs).

For information on the family of BT300 VFDs, see the *BT300 HVAC Drives Submittal Sheet* (154-126), and *BT300 HVAC Drives Technical Specification Sheet* (149-711).

### BT300 E-Bypass Features

- Bypass Start-up Wizard
- Diagnostic board with test points
- Control logic short circuit protection
- 100,000 AIC short circuit rating
- Auto Bypass
- Damper Interlock
- Essential Service Mode
- Remote Bypass
- Electronic Override
- View/Monitor bypass parameters
- Multiple Safeties
- Monitor and display which safety interlock is open
- Control external devices via serial communication
- Pass through I/O capabilities command up to 8 output points
- View status of I/O points
- Supports APOGEE P1, BACnet and Modbus protocols in bypass
- Compact design

### 2-Contactor: Output and Bypass

- Overload protection in bypass mode
- Electrically interlocked

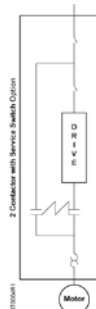

### Drive Isolation

Drive Service Switch allows the drive to be disconnected from power during troubleshooting without disrupting bypass operation.

### Input Device

- Fused disconnect
- Circuit breaker (optional)
- All doors are interlocked and can be padlocked

### 5% Input Impedance

- Internal reactors lower harmonics that the drive produces.
- BT300 E-Bypass requires no additional input reactors

### E-Bypass Control Features

#### Auto Bypass

- Relay logic allows User to send the motor to bypass mode based on the drive's programmable fault list.
- Customer defines the events which will transfer to bypass.
- The drive's programmable relay can be set up for applications that run full speed for an extended period of time.

#### Damper Interlock

- Generally used for safety tie-ins; the motor will not operate the drive or bypass when open.
- Enables a circuit signaling the system is ready for bypass.

#### Essential Service Mode

- Also used for smoke purge; the motor goes to bypass regardless of the selected mode.
- No call to stop will have an effect, including open safety or stop commands.
- Only turning the power off or opening this contact will stop the motor.

#### Remote Bypass

Customer-supplied start/stop controls when running in bypass.

#### Electronic Override

- Full bypass control, even if the control board (intelligence) fails. As long as power is supplied to the bypass, you have full bypass capability.
- Maintains all system safeties in bypass.

**Product Numbers**

Example Product Numbers		B	T	E	-	0	0	1	X	2	-	F	0	1	2	
		B	T	C	-	0	0	7	5	4	-	B	0	1	3	L
<b>Bypass Models</b>		BTC		Conventional												
		BTE		Electronic												
<b>HP</b>																
				1, 1.5, 2, 3, 5, 7.5, 10, 15 20, 25, 30, 40, 50, 60, 75												
				<b>NOTE:</b> 208V only up to 40 HP												
				X=no fract HP, 5=1/2 HP												
<b>Voltage</b>																
		2		208 to 240												
		4		380 to 480												
<b>Disconnect</b>																
		F		Fused Disconnect												
		B		Circuit Breaker												
<b>NEMA</b>																
		01		UL Type 1												
<b>Type</b>																
		3		3 contactors (input, output and bypass) (for C Bypass only)												
		2		2 contactors (output, bypass) w/ service switch												
<b>Options</b>																
		L		Lon card installed												

**Table 1. E-Bypass Approximate Weights.**

Frame	Weight lb (kg)
FS4	50 (23)
FS5	69 (31)
FS6	112 (51)
FS7	187 (85)

**NOTE:** Exact weight will be affected by actual horsepower/voltage and selected power options.

**Typical Specifications**

BT300 E-Bypass Options shall send the motor to bypass mode based on an easily accessible door-mounted selector or based on User's desired conditions. The bypass mode shall provide overload protection. Contactors shall be electrically interlocked. An essential services mode shall send the motor to bypass regardless of the selected mode. When in safety modes it should provide indication of return state. It should indicate interlock sequence state during transition. Visually indicate faults for VFD safety/overload. In case of catastrophic failure, bypass and safeties must be provided.

**Table 2. E-Bypass Frame Sizes and Power Ranges per NEC Motor Tables.**

		Current Ratings			Frame Size		
HP	kW	208	230	480	208	230	480
1	0.75	4.6	4.2	N/A	FS4		N/A
1.5	1.1	6.6	6	3			N/A
2	1.5	7.5	6.8	3.4			FS4
3	2.2	10.6	9.6	4.8			FS4
5	4	16.7	15.2	7.6	FS5		
7.5	5.5	24.2	22	11			
10	7.5	30.8	28	14	FS6		FS5
15	11	46.2	42	21			
20	15	59.4	54	27	FS7		FS6
25	18.5	74.8	68	34			
30	22	88	80	40	N/A		FS7
40	30	114	104	52			
50	37			65	N/A		
60	45	N/A		77			FS7
75	55			96			

**NOTE:** Drives are current (amperage) rated devices. Verify that the listed ratings are  $\geq$  the motor full load current rating.

**Dimensions**

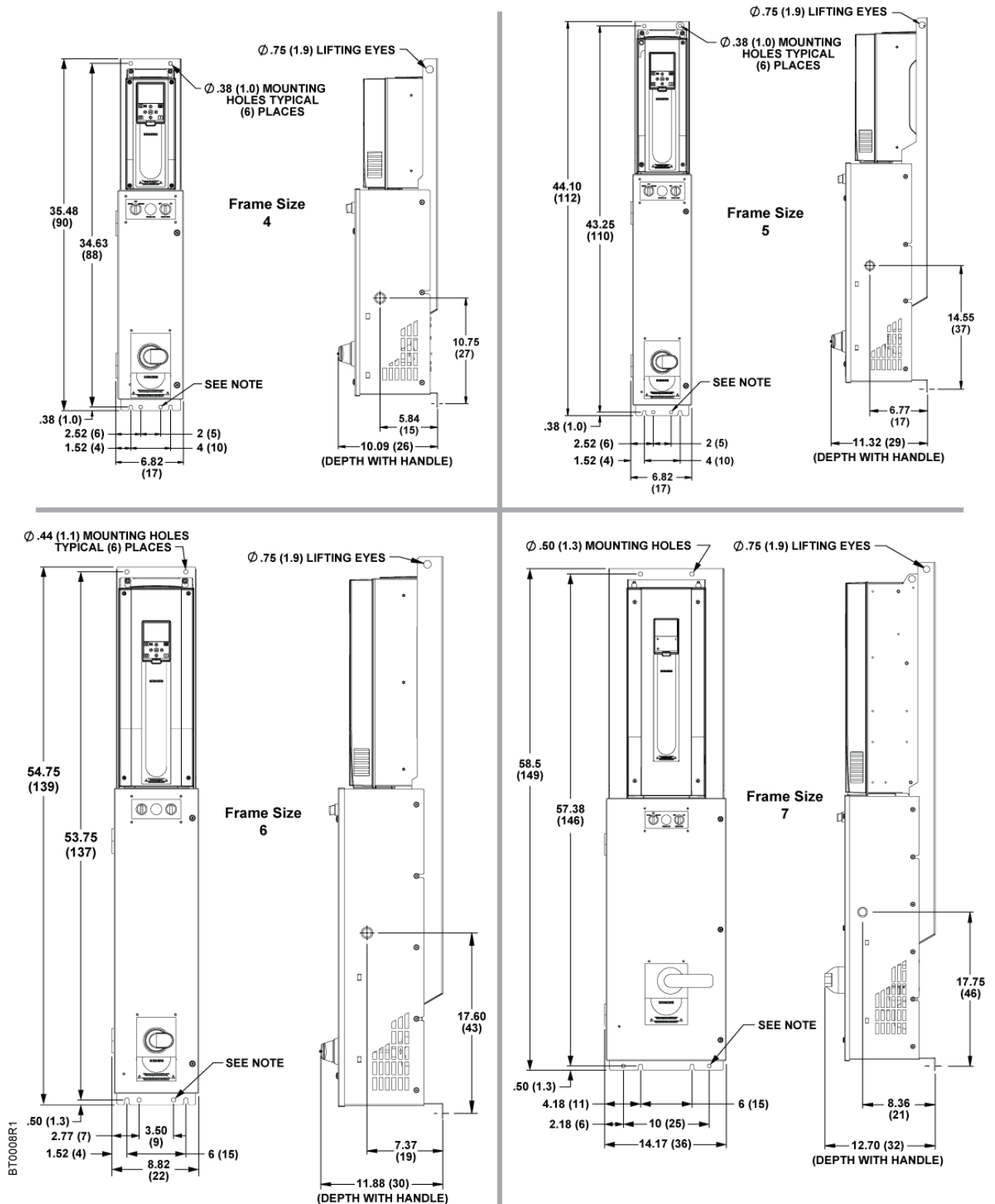

NOTE: USE MOUNTING HOLES INSTEAD OF SLOTS IN INSTALLATIONS THAT ARE PRONE TO SEISMIC ACTIVITY.

**Figure 1. E-Bypass Dimensions in Inches (cm).**

## Wiring Diagrams

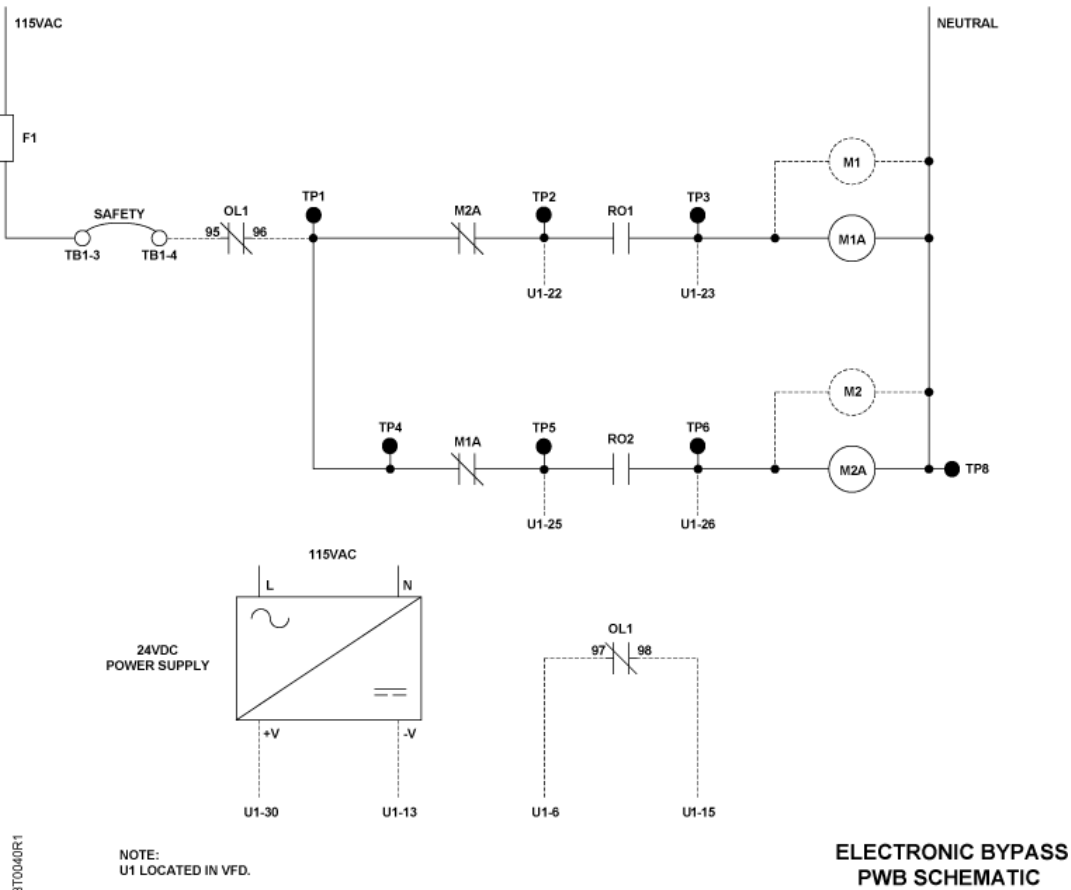

### NOTES:

1. Branch circuit protection to be provided by installer, per UL508A, if not provided with drive.
2. Control and communication wiring should be 300V UL minimum.
3. Communication wiring should be run with maximum separation possible from all other wiring.
4. Essential service mode operates the motor full speed (bypass) with no protection for the motor or system.
5. Ensure that automatic bypass will not damage the system before activating.
6. See *Siemens BT300 Bypass Operator's Manual* (DPD01391) for proper fuse and wire sizes.
7. See *Siemens BT300 Operator's Manual* (DPD01149) for BT300 input/output control signal wiring details.

**Figure 2. E-Bypass Power Circuit.**

Wiring Diagrams, Continued

FUSED DISCONNECT VERSION FS07-FS09

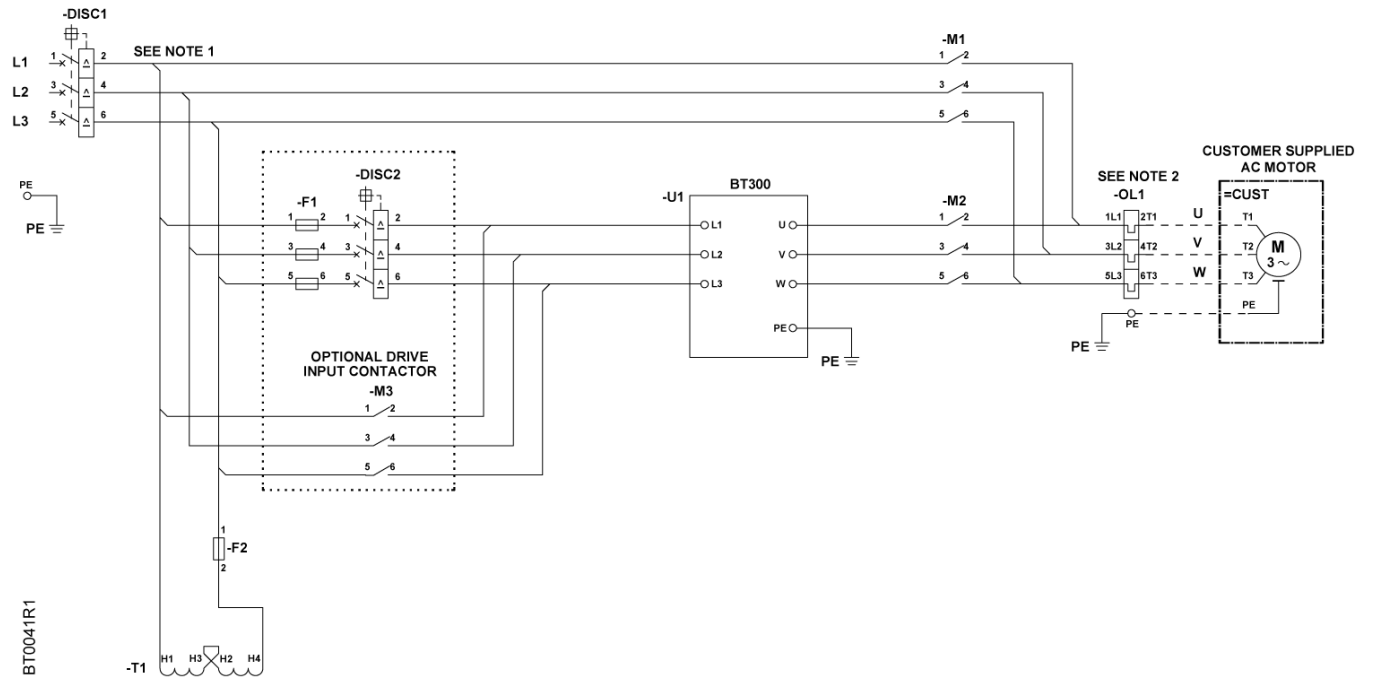

Figure 3. Power Wiring.

Wiring Diagrams, Continued

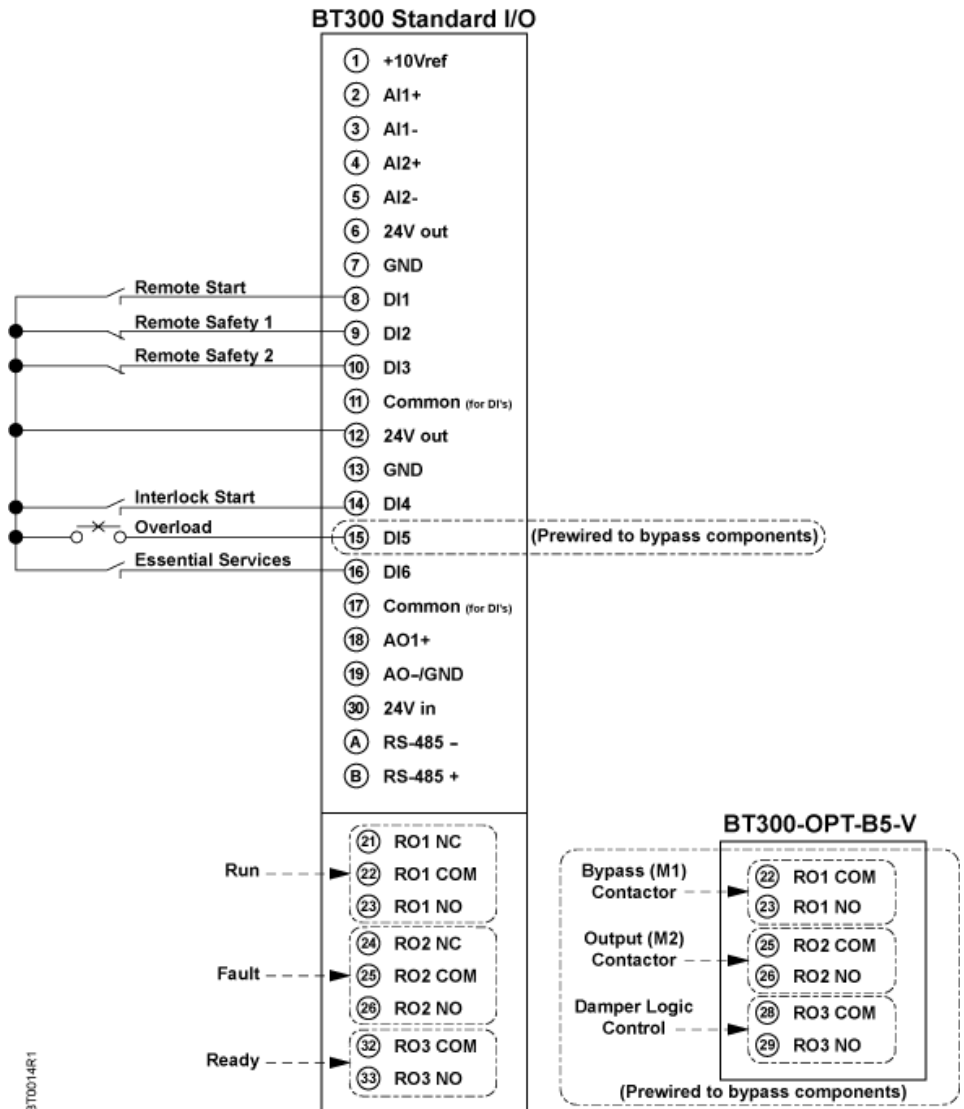

Figure 4. E-Bypass Controller Board Digital Inputs and Outputs.

**Table 3. E-Bypass Specifications.**

Specifications	Description
Input Voltage (3-phase)	208V, 3 AC±10%. 1 hp to 40 hp (3.9 amps to 105 amps) 480V, 3 AC ±10%. 1 hp to 75 hp (2.1 amps to 105 amps)
Standard Bypass I/O Analog Inputs Analog Output	2: Voltage or current (up to 10 Vdc, 0/4 to 20 mA) 1: Selectable voltage or current
Digital Inputs	All Digital Inputs are fully programmable. Defaults are configured as follows: <ul style="list-style-type: none"> <li>• Remote start input</li> <li>• Remote safety 1</li> <li>• Remote safety 2</li> <li>• Interlock start</li> <li>• Essential services</li> <li>• Overload trigger</li> </ul> Inputs require a contact closure capable of providing a low impedance path at currents less than 20 mA.
Relay/Digital Outputs	All Relay/Digital Outputs are fully programmable. Defaults are configured as follows: <ul style="list-style-type: none"> <li>• VFD fault</li> <li>• Programmable output</li> <li>• Drive select</li> <li>• Bypass select</li> <li>• Running on bypass</li> <li>• Overload fault</li> </ul> Each relay has a maximum rating of 2A at 120 Vac.
Short Circuit Withstand Rating	100,000 AIC
Temperature	Ambient Operating: 14° F (-10°C) no frost to 104°F (40°C) without de-rating and 131°F (55°C) with de-rating Storage: -40°F to 158°F (-40°C to 70°C)
Relative Humidity	0 to 95% RHJ, non-condensing, non-corrosive
Air Quality	IEC 60068-2-60
Chemical Vapors	IEC 60721-3-3, unit in operation, class 3C3
Mechanical Particles	IEC 60721-3-3, unit in operation, class 3S2
Altitude	100% load capacity (no de-rating) up to 3,280 ft (1,000 m) 1% de-rating for each 328 ft (100 m) above 3,28 ft (1,000 m) Maximum altitude 14,763 ft (4,500 m)
Vibration	IEC 61800-5-1 and IEC 60068-2-6
Seismic	2012 International Building Code (IBC)
Shock	IEC 61800-5-1 and IEC 60068-2-27
Enclosure	UL Type 1
Agency Approvals	UL 508C
Auxiliary Input Voltage	24 Vdc
Auxiliary Output Voltage	24 Vdc at 50 mA maximum
Serial Interface Embedded Resident Protocols	RS485 and Ethernet Modbus RTU, Modbus TCP; BACnet MSTP, BACnet IP; N2 All in either Drive or Electronic Bypass
Protection features	Under-voltage trip limit, Over-voltage trip limit, Ground fault protection, Mains supervision; Motor phase supervision; Over-current protection; Unit over-temperature protection; Motor overload protection; Motor stall protection; Motor underload protection; Short-circuit protection of +24V and +10V reference voltages.

**Table 4. Order Worksheet.**

Item	Qty.	Designation	Part Number	Description

Information in this publication is based on current specifications. The company reserves the right to make changes in specifications and models as design improvements are introduced. Product or company names mentioned herein may be the trademarks of their respective owners. © 2014 Siemens Industry, Inc.